



Hi,



I am your  
instruction  
manual.

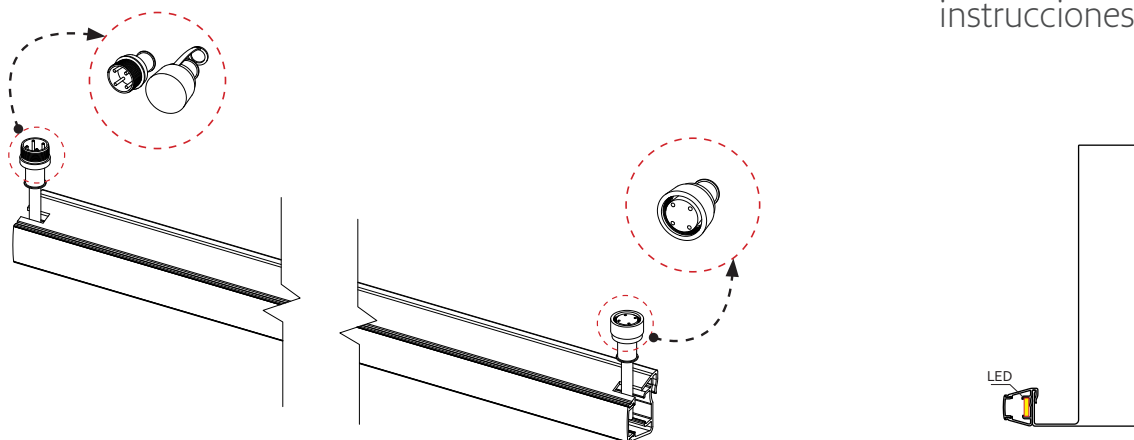

Nice to meet you

montage instructies  
 montageanleitung  
 instructions de montage  
 instrucciones de montaje

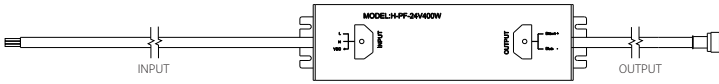

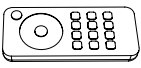
Reference	Parts	Quantity
E-W3	Waterproof joint(3) 	1
E-T	Transformer 	1
L-C	LED Controller 	1
L-LC	LED remote rematches 	1



Sharing the  
 sun together

Nice to meet you

montage instructies  
montageanleitung  
instructions de montage  
instrucciones de montaje

## Wiring Diagram

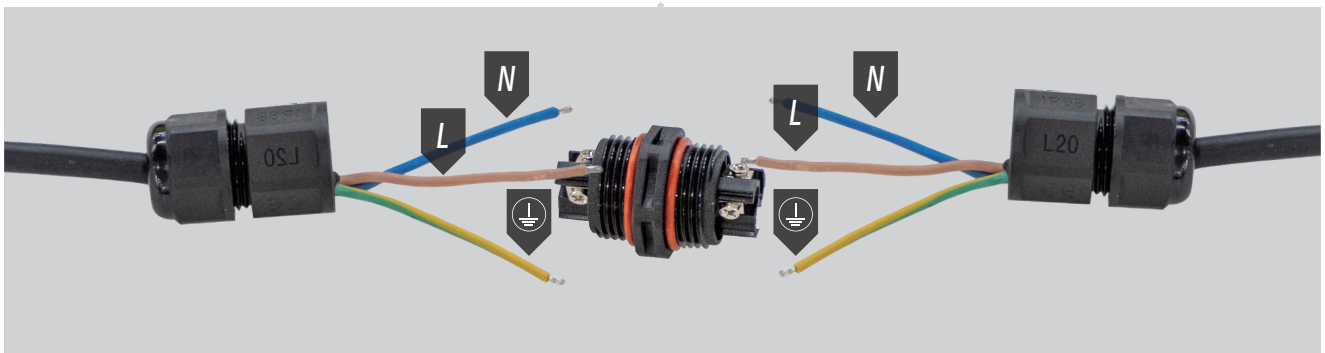
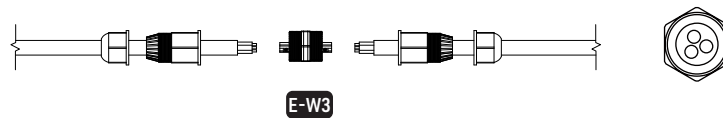
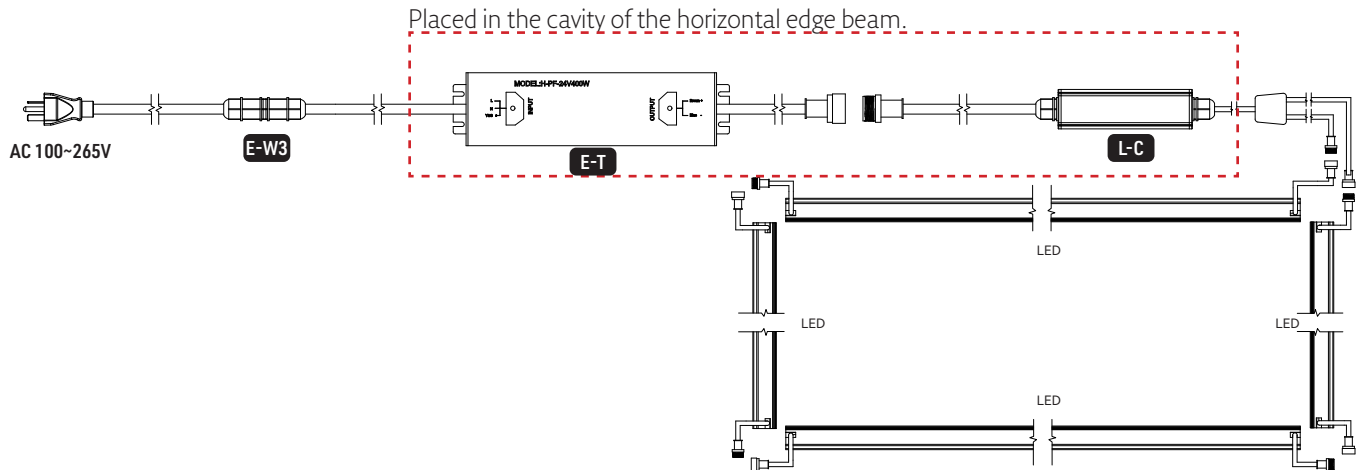

There are 3 cables at the input end of the power, namely:

Brown: LIVE WIRE

Blue: NEUTRAL WIRE

Yellow & Green: EARTH WIRE



Sharing the  
sun together

Nice to meet you

montage instructies  
montageanleitung  
instructions de montage  
instrucciones de montaje

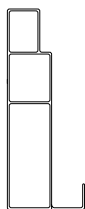

Placed in the cavity of the horizontal edge beam.

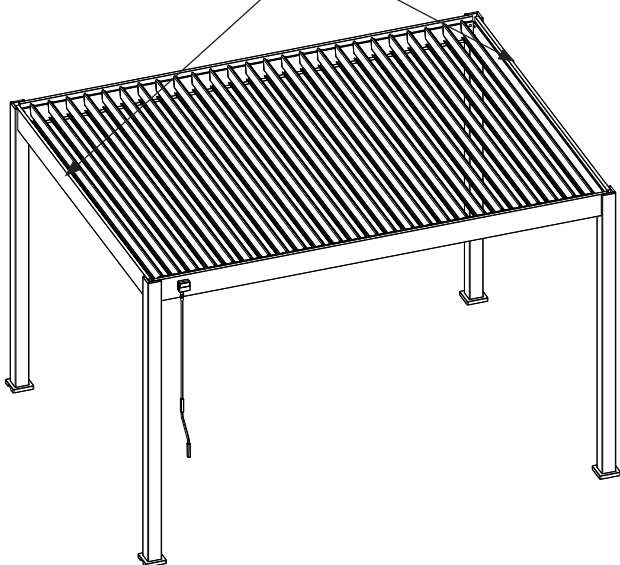

Placed in the cavity of the horizontal edge beam.

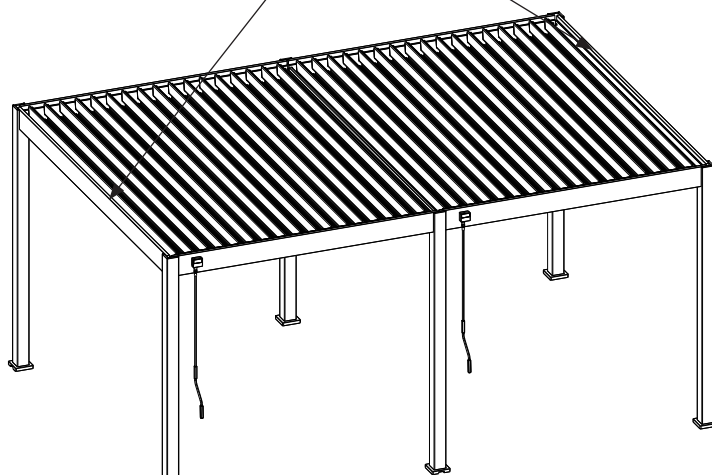

Placed in the cavity of the horizontal edge beam.



Placed in the cavity of the horizontal edge beam.

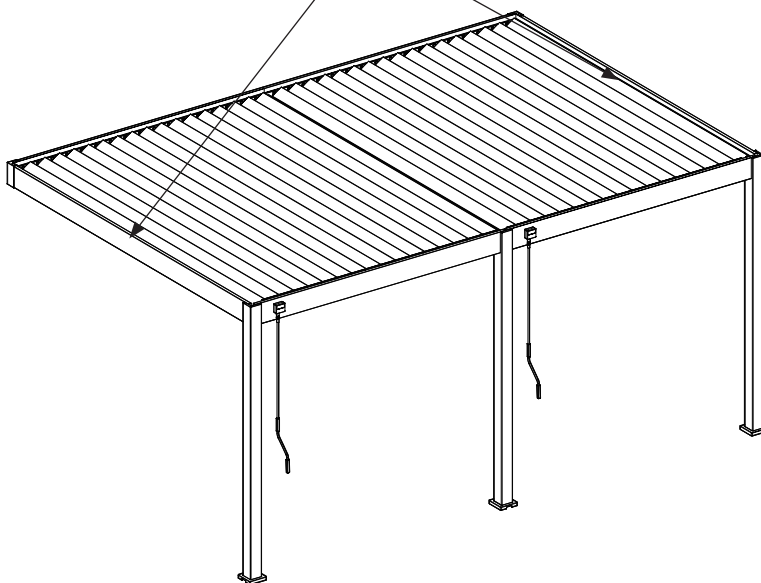

Sharing the  
sun together

Nice to meet you

montage instructies  
montageanleitung  
instructions de montage  
instrucciones de montaje

There are two cases of installation.

Case 1: When pergola is not installed, please install the related accessories of the LED according to the plan A.  
Case 2: When pergola has been installed, please install the related accessories of the LED according to the plan B.

### Plan A -when pergola is not installed

- Please insert the input line of the transformer into the cavity of the post
- Pull the input line from the drainage outlet of the post
- Install the plate and skirt of the post after pulling out the input line

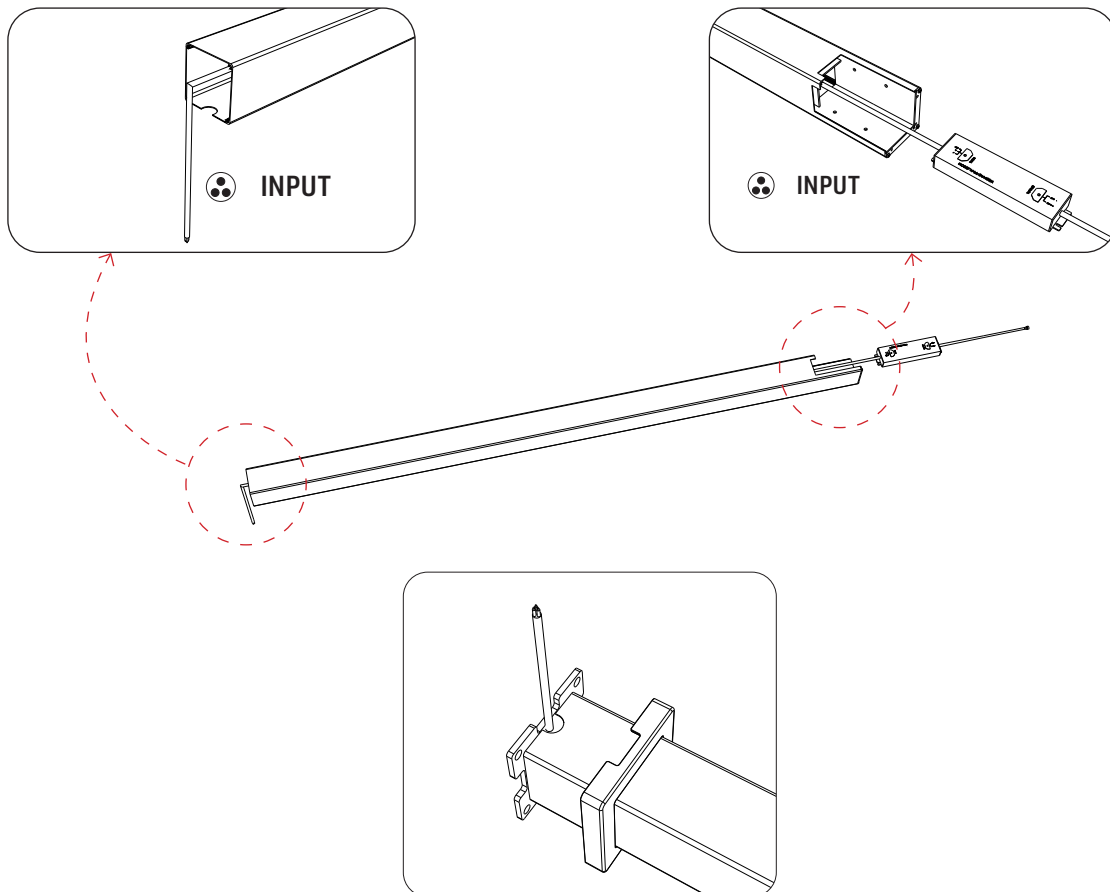

Sharing the  
sun together

Nice to meet you

montage instructies  
montageanleitung  
instructions de montage  
instrucciones de montaje

Plan A -when pergola is not installed

Place the transformer according to the figure, and then install the posts and beams.

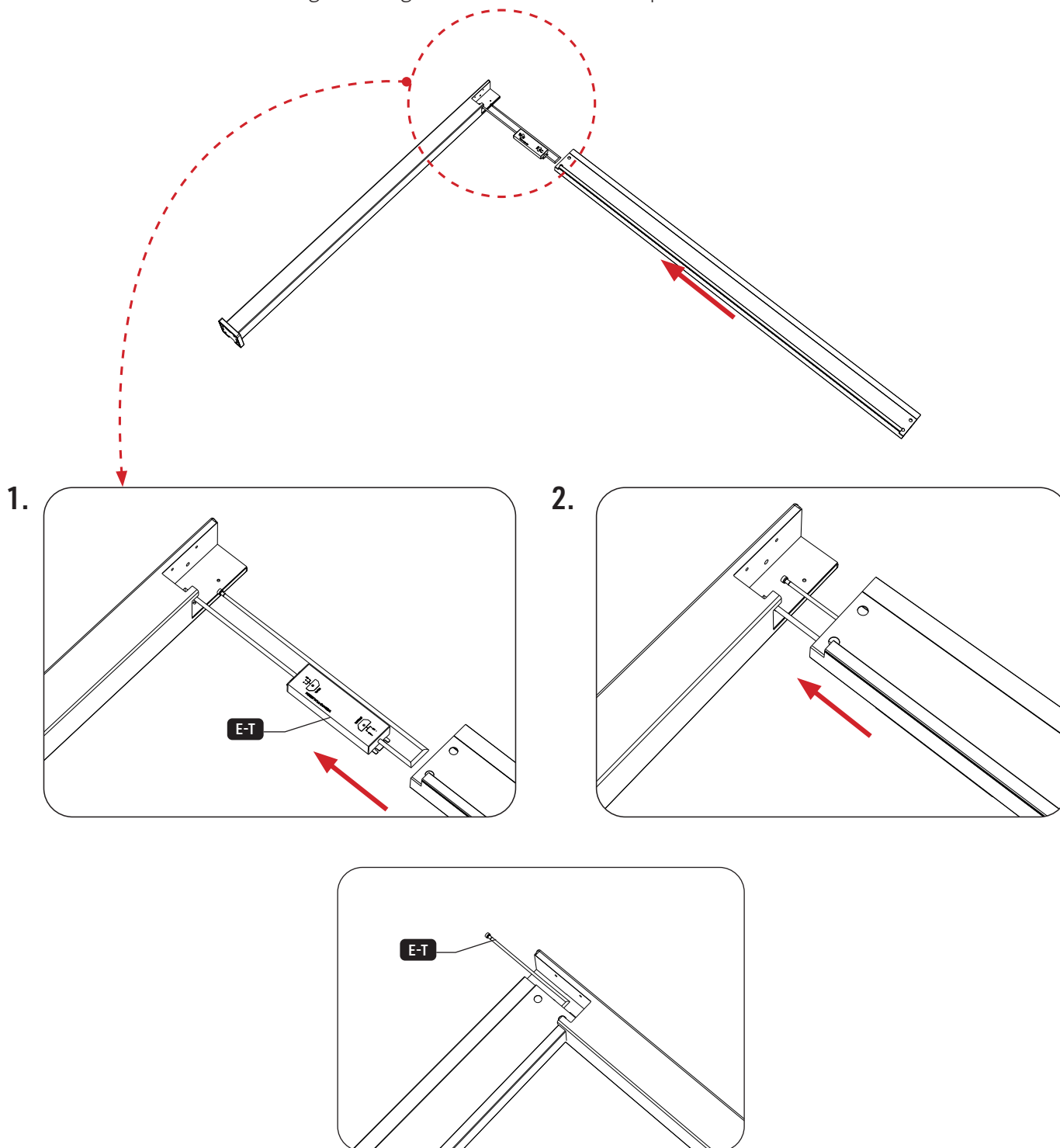

Sharing the  
sun together

Nice to meet you

Plan B - when pergola has been installed

montage instructies  
montageanleitung  
instructions de montage  
instrucciones de montaje

Remove the side beam where the transformer is installed and the louvers near the side beam.

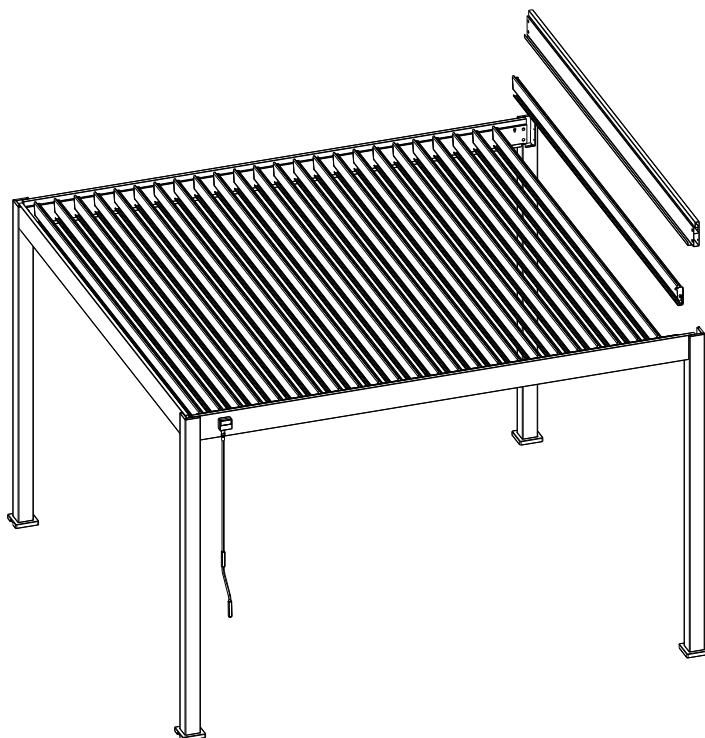

Put the transformer into the removed side beam, pull the transformer input cable out of the drainage hole of the post, and place the output cable at the top.

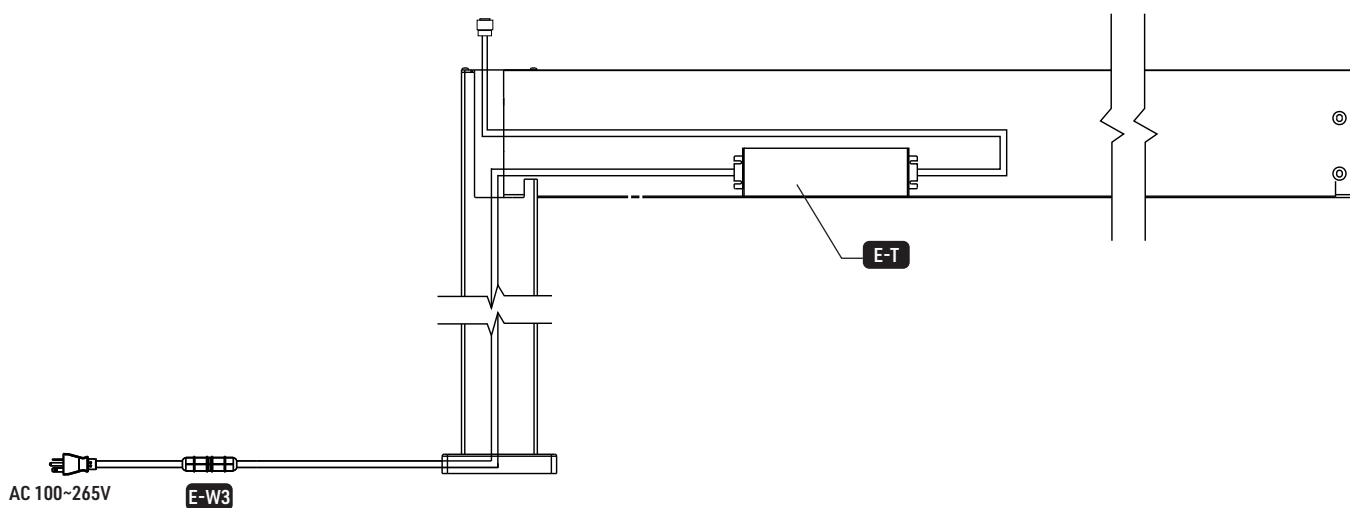

Sharing the  
sun together

Nice to meet you

Place LED controller  
Place the LED controller in the cavity of the post

montage instructies  
montageanleitung  
instructions de montage  
instrucciones de montaje

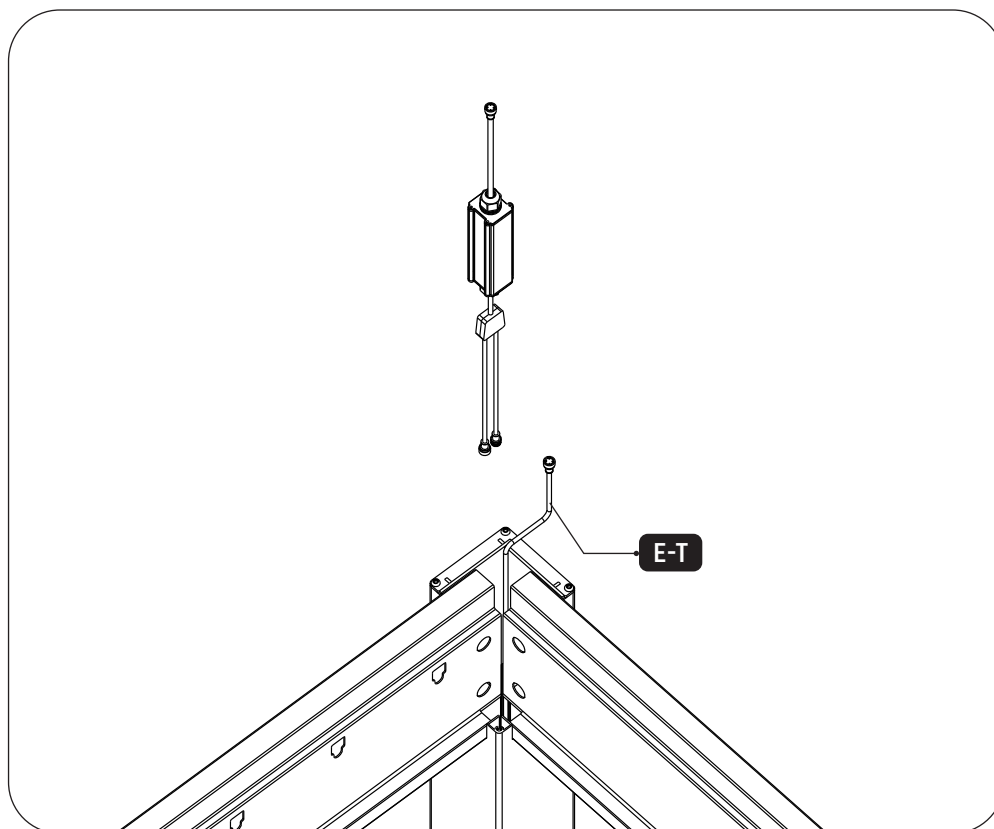

Connect the controller to the transformer, pull out the output end of the controller from the shown position to facilitate the subsequent connection of the troffer

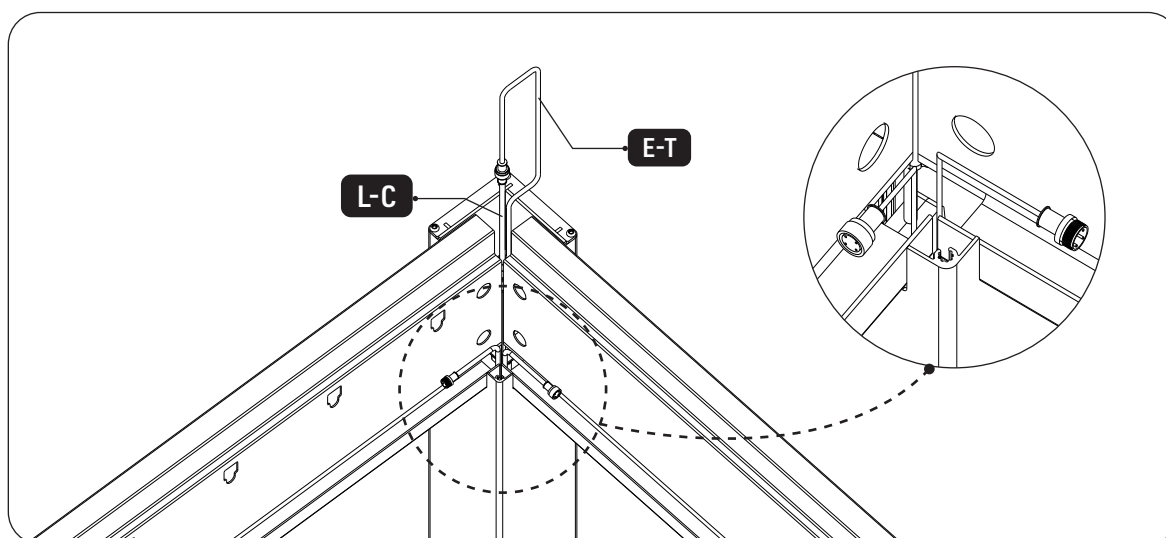

Sharing the  
sun together



Nice to meet you

Place the tape lights  
Connect the controller to the tape lights.

montage instructies  
montageanleitung  
instructions de montage  
instrucciones de montaje

Connect the LED Controller

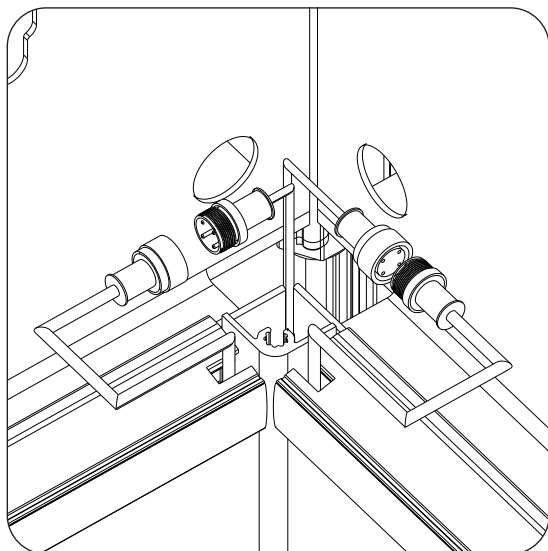

Connect the LED

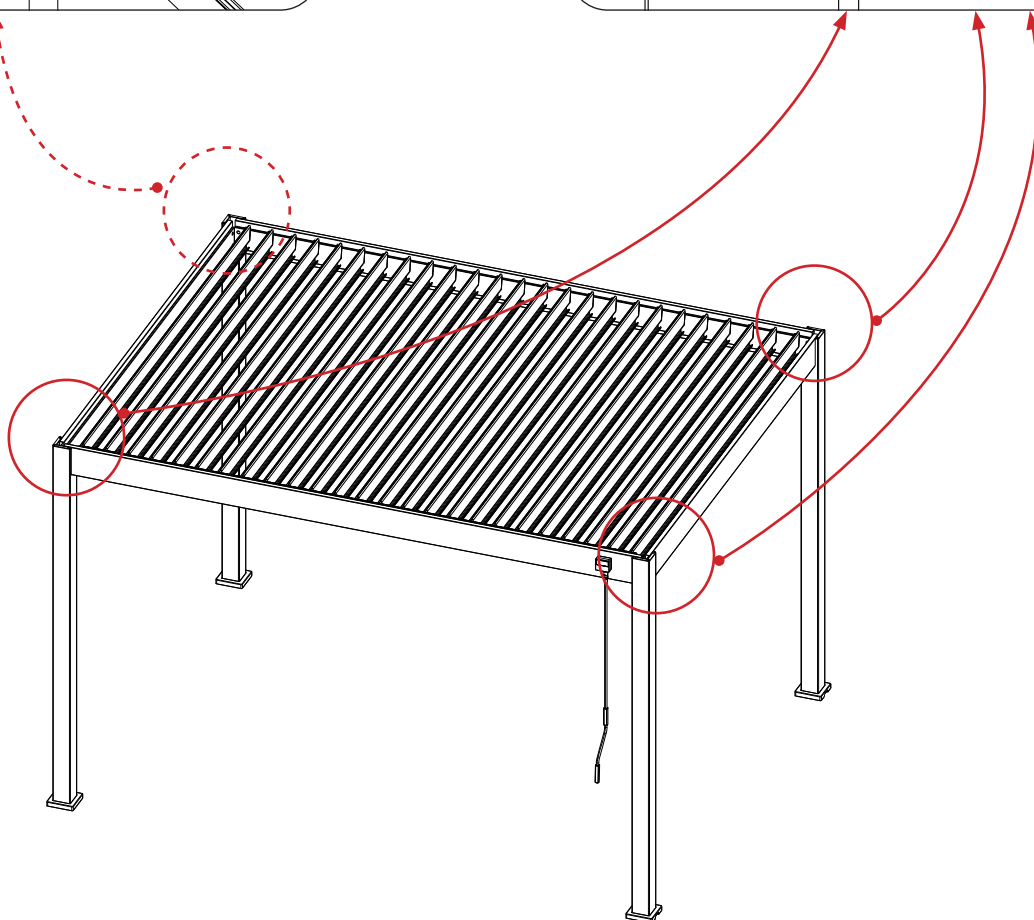
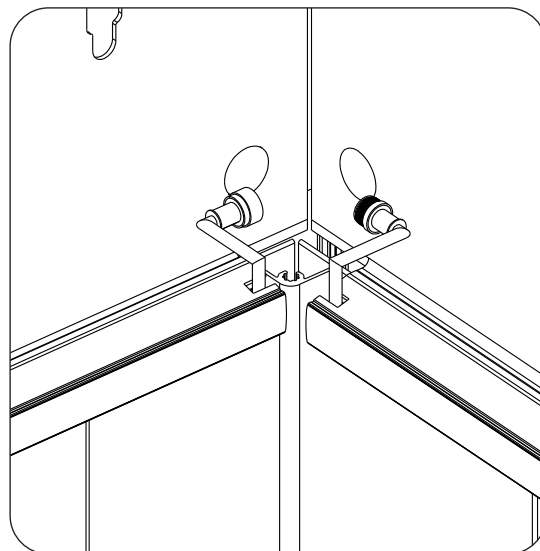

Sharing the  
sun together

Nice to meet you

montage instructies  
montageanleitung  
instructions de montage  
instrucciones de montaje

LED remote rematches

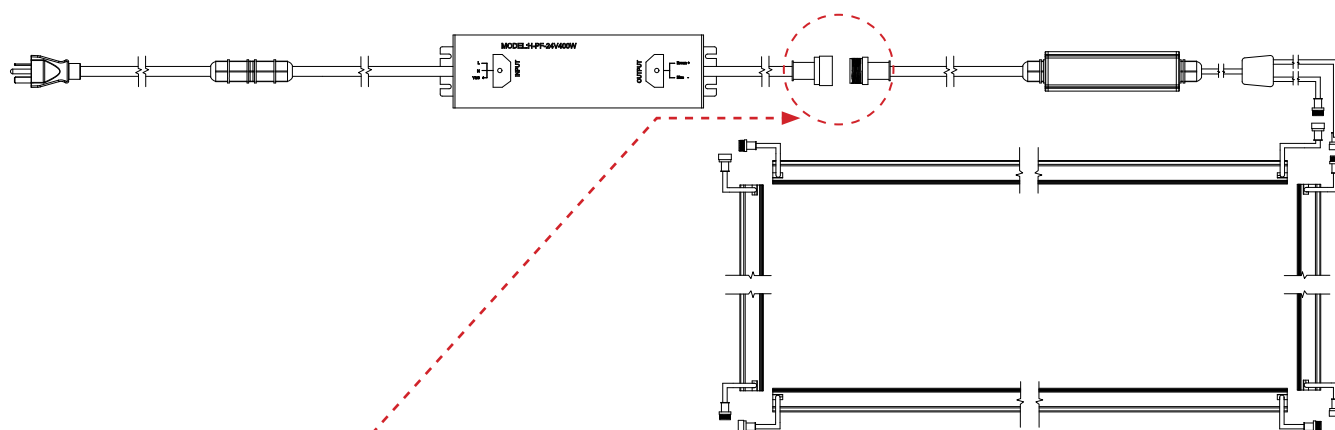

**To match the remote, switch off the power, then switch on power, repeat again.** Immediately short press 3 times on off key. To delete the remote, switch off the power, then switch on power, repeat again. Immediately short press 5 times on off key.



Sharing the  
sun together



Sharing the  
sun together